

(No Model.)

E. LINDNER.
TURNING LATHE.

No. 377,080.

Patented Jan. 31, 1888.

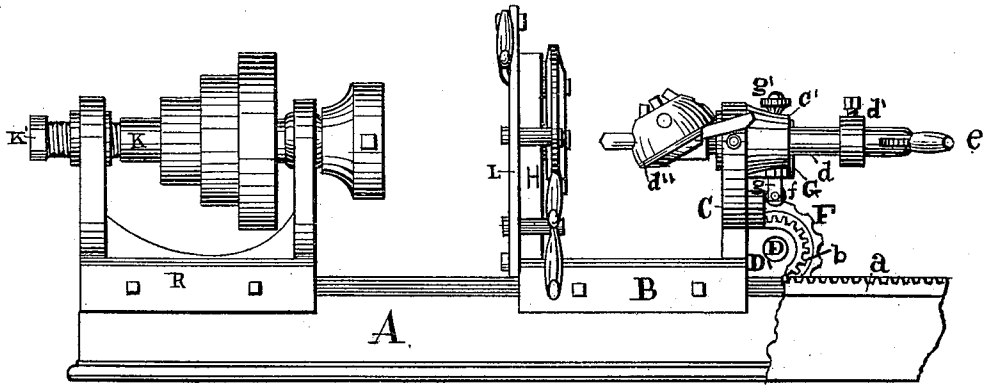

FIG. 1.

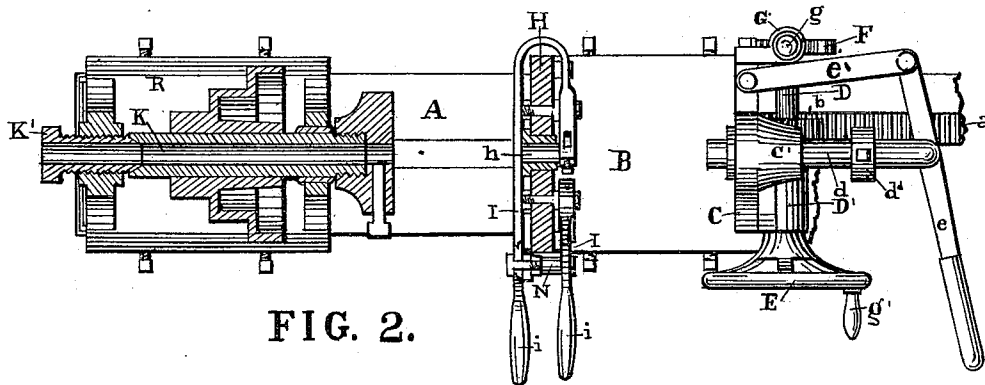

FIG. 2.

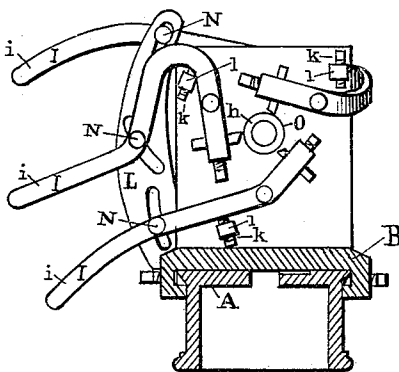

FIG. 3.

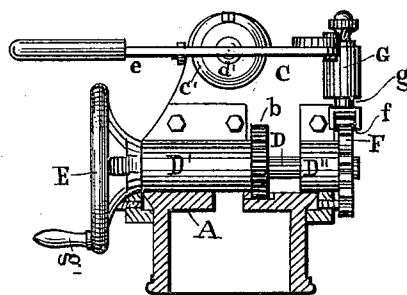

FIG. 4.

WITNESSES:
C. F. Kelly
D. J. Shea

INVENTOR
Ernst Lindner
BY
C. F. Conner
ATTORNEY

UNITED STATES PATENT OFFICE.

ERNST LINDNER, OF NEW YORK, N. Y., ASSIGNOR OF ONE-HALF TO THE
E. P. GLEASON MANUFACTURING COMPANY, OF SAME PLACE.

TURNING-LATHE.

SPECIFICATION forming part of Letters Patent No. 377,080, dated January 31, 1888.

Application filed May 9, 1887. Serial No. 337,662. (No model.)

To all whom it may concern:

Be it known that I, ERNST LINDNER, a citizen of the United States, and a resident of New York, in the county and State of New York, have invented a new and useful Improvement in Turning-Lathes, of which the following is a specification.

My invention relates to turning-lathes of that class known as "chuck" or "hollow" live-spindle lathes; and it has for its object the increasing of the capacity of the lathe both in variety and rapidity of its operations.

My invention consists in providing a lathe with a sliding tail-stock having a vertical flange or plate provided with a socket-hole adapted to receive one of several interchangeable guiding-bushings, also provided with movable tool-holders and operating-levers, and which tail-stock is also adapted for progressive adjustment along the bed or shears by means of suitable moving, gaging, and locking mechanism, together with the novel combination and arrangement of parts, all of which will more fully appear, reference being had to the following specification, of which the accompanying drawings form a part, in which—

Figure 1 is a face view of a portion of a turning-lathe having my improved sliding tail-stock. Fig. 2 is a top view of the same portion, some parts being shown in section. Fig. 3 is an elevation of the vertical flange or plate forming part of the sliding tail-stock. Fig. 4 is an end view of the sliding tail-stock.

Like letters designate like parts in all the figures.

A is the lathe bed or shears, made in the ordinary way, except that on its upper face, extending longitudinally most of its length, is a cog-rack, *a*, which may be an independent piece, adapted to engage with a pinion, *b*, attached to the sliding tail-stock B. This sliding tail-stock B consists of a base-plate, the under side of which is provided with suitable guiding grooves or flanges to maintain it in position on the bed A. From each of its ends an upright flange extends a suitable height, the rear upright flange, C, terminating at its top in a hub or bearing, C', in which the tool-stock or dead-spindle *d* is fitted to slide. This tool-

stock *d* is provided with an adjustable collar, 50 *d'*, which serves to gage or limit its motion. It is operated by a hand-lever, *e*, which is pivoted to its outer end and connected by a link, *e'*, to the upright flange C. The forward end of the tool-stock *d* is adapted for the attachment of a turret-head tool-holder, as is shown 55 at *d''*, by the ordinary means, which also adapts it for holding various tools and chucks.

The turret-head tool-chuck *d''* may be of any approved make to be found on sale. I prefer 50 T. R. Almond's patent, August 17, 1875, positioned so as to hold the operative tool longitudinally parallel to and on the line of the axis of the lathe or socket O. It may be re- 65 volved by hand to bring any one of the several tools which it is adapted to carry into operative position.

At the base of the upright flange C on the rear end of the sliding tail-stock is attached a shaft, D, by suitable bearing-boxes, D' and D''. This shaft carries the pinion-gear *b*, 70 which is fitted in position and adapted to engage with the cog-rack *a* on the bed A. Motion is given to this shaft D through a hand-wheel, E, which is fixed on its front end. 75 Fixed on its rear end is one of several interchangeable indexing or gaging wheels F, which has notches at equal spaces in its periphery, into which a roller, *f*, which is carried on the lower end of a spring-actuated bolt, *g*, is made 80 to catch. This bolt *g* slides vertically in a bearing-box, G, which is firmly attached to the upright flange C of the sliding tail-stock B, thus forming the progressive feeding, gaging, and locking mechanism. 85

It will be observed that rotating force applied on the hand-wheel E will be communicated through the shaft D to the pinion *b* and index-wheel F. The pinion *b*, engaging with the cog-rack *a*, will cause the advance of the sliding tail-stock B. Simultaneously the index-wheel F will cause the roller *f* to revolve and the bolt *g* to rise and release the catch of the roller until a succeeding notch comes to position for it to catch again, thus gaging the 90 advance of the sliding tail-stock B and locking it in position.

The upright flange H at the forward end of

the sliding tail-stock B has a circular socket-hole, O, through it, adapted to receive and hold in position in line with the axis of the lathe-spindle K one of several interchangeable bushings *h*, the use of which will be explained hereinafter. To this upright flange H, on its inner side, are pivoted levers I I I, the shorter arms of which are shaped so as to adapt them for holding any of the forming-tools required in the various operations of the lathe in such position that when the hand end *i* of a lever is pressed downward the tool held in the other end will be advanced toward the axis line of the bushing *h* until the motion is arrested by an adjustable stop-screw, *k*, which is secured to the upright flange by a lug, *l*, as shown. Any suitable means may be employed for clamping or fixing in place such tools as may be used in the short end of said levers as will admit of their adjustment to or from the axis of the socket O, so that while one may be set so its cutting-edge will but skim the surface of the material being worked another may be set to cut deeply and form grooves, beads, or other forms, and another set to cut clear to the axis of the lathe or socket O, and thus serve to sever the finished portion from the material. These levers I I I are bent, as shown, so as to bring the handle ends *iii* to the front of the sliding tail-stock B in a convenient position for operating, and so they will not interfere with each other. A plate, L, in which are slots concentric with the pivots of each respective lever, is fixed to the front edge of the flange H. Bolts N pass through these slots to each lever, respectively, by which the levers may be firmly clamped in position when desired.

The upright flange H may be made separate from the base-plate and be adjustable, so that longer or shorter pieces may be shaped by setting this flange farther from or nearer to the rear flange, C, on the base-plate B. This may be done by set-screws, which secure it in position, or in any well-known manner.

The spindle K and the step K' of the live head-stock R should be hollow, so as to adapt them for the passage of the rod of material to be worked. The forward end of the spindle K should be provided with an adjustable chuck or an adjustable coupling device suitable to clamp the material to be worked, so it will revolve with it.

This operation of the lathe is as follows: The sliding tail-stock B being at the end of the bed A, a rod of material to be worked is passed through the spindle K until its end reaches and enters through the bushing *h* in the upright flange H of the sliding tail-stock B. This bushing *h* should be of proper size to adapt it to perform the functions of a journal box or bearing to the rod of material, which is then clamped at the spindle K, so as to cause it to revolve. Now, when the

spindle K is revolving, any tools—*i. e.*, drills, taps, &c.—which are carried by the tool-stock *d''* may be advanced against the butt-end of the rod of material by pulling the hand-lever *e* until motion is arrested by the collar *d'* on the tool-stock *d* striking the hub C. Then in turn the tools held by the levers I I I on the flange H may be advanced to do their work in the manner as above stated, the last one cutting the finished piece from the rod. Then the sliding tail-stock B is advanced toward the spindle K in the manner before stated, thus getting the proper length of the rod of material through the bushing *h* to make another finished piece of work, the above-stated operation being repeated until the sliding tail-stock B progresses to the spindle K, whereupon the rod of material is unclamped, the sliding tail-stock moved back to the end of the lathe, the rod of material again adjusted and clamped, and a succeeding operation commenced.

To facilitate the back movement of the sliding tail-stock, the locking-bolt *g* is held up by the operator with one hand, while with the other he revolves the hand-wheel E, (a suitable knob, *g'*, for the purpose being attached to it.)

Having thus described my invention, what I claim as new, and desire to secure by Letters Patent, is—

1. The sliding tail-stock of a turning-lathe, consisting of a base-plate, as B, upright flange, as H, provided with the socket-hole O for holding interchangeable bushings, and the upright flange C, having the hub C', in combination with the tool-stock *d*, having suitable means for operating the same, arranged in the manner and for the purpose substantially as set forth.

2. The sliding tail-stock of a lathe, consisting of a base-plate, as B, upright flange, as C, terminating in the hub C', and the upright flange, as H, provided with a socket, O, for interchangeable bushings, in combination with the bed of a lathe, as A, and suitable means of adjusting said sliding tail-stock thereon.

3. The combination of the sliding tail-stock of a turning-lathe with the progressive feeding, gaging, and locking mechanism hereinbefore described, to wit: a shaft, as D, bearings, as D' D', pinion, as *b*, index-wheel, as E, bolt, as *g*, and bearing, as G, arranged in the manner substantially as shown, and for the purpose set forth.

4. The upright flange H, in combination with the bed A and rack *a* of a turning-lathe, with its pivoted lever tool-holders I I I and socket-hole O, adapted for receiving and holding interchangeable bushings, said flange being rigidly connected, so as to form part of the sliding tail-stock of the lathe.

5. In turning-lathes, a live head-stock having a hollow spindle, and a bed or shears hav-

ing a cog-rack adapting it to receive and operate in conjunction with progressive feeding, gaging, and locking mechanism, in combination with a sliding tail-stock having such mechanism attached, the same being arranged substantially in the manner and for the purpose specified.

In testimony that I claim the foregoing as my invention I have signed my name in presence of two witnesses.

ERNST LINDNER.

Witnesses:

ELIAS WHITNEY,
E. F. GENNERT.